

*“The Versatile Round & Oval Duct Connector”*

# AIR-FLANGE



*AIR-DUCT MFG., INC. introduces AIR-FLANGE*

- Available in single wall and double wall, Round & Oval
- 10"– 94" Diameter round sizes
- Custom & odd sizes available
- Available in galvanized, paint-lock, stainless, aluminum & PVC coated
- Durable 18 - 14 gauge construction
- More economical than competing connectors
- Fast & simple Tek screw connection
- Many sizes in stock for quick shipping
- Cost savings on field Labor

*“AIR-FLANGE is a key component we use to save on labor in the field”*

*- California HVAC Contractor*

\*While SMACNA does not evaluate or endorse any proprietary products, they encourage the development of new HVAC products and technology, and set standards and guidelines for products to meet.

## AIR-DUCT MFG., INC.

920 N. LOMBARD RD.  
LOMBARD, IL 60148

Ph: 630-620-9866  
Fx: 630-620-9878

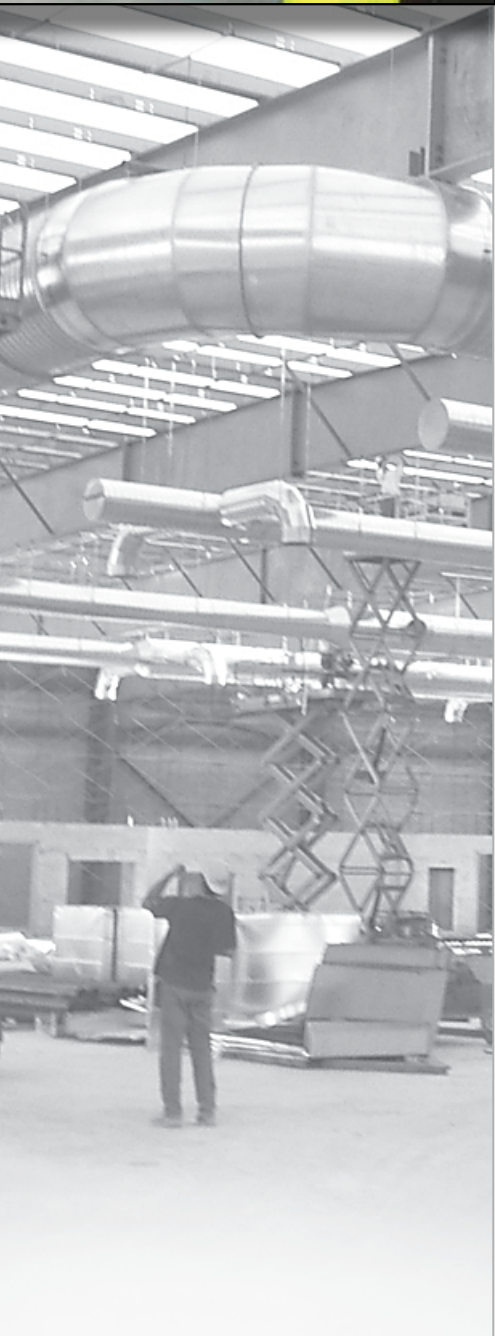

# AIR-FLANGE

## Round AIR-Flange Submittal

### AIR-Flange SINGLE WALL

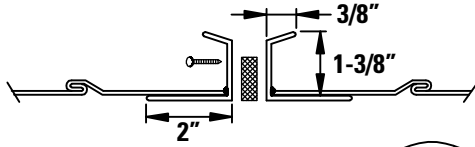

The use of AIR-Flange connecting system, installed and sealed per manufacturer's recommendations, is suitable for use on all systems across a range of internal duct pressures from 10" S.P.W.G. positive to 6" S.P.W.G. negatives.

**GAUGES:**

10"-62"... 18 gauge

64"-74"... 16 gauge

76"-94"... 14 gauge

5/16" thick by 3/4" wide closed cell neoprene gasket by others.

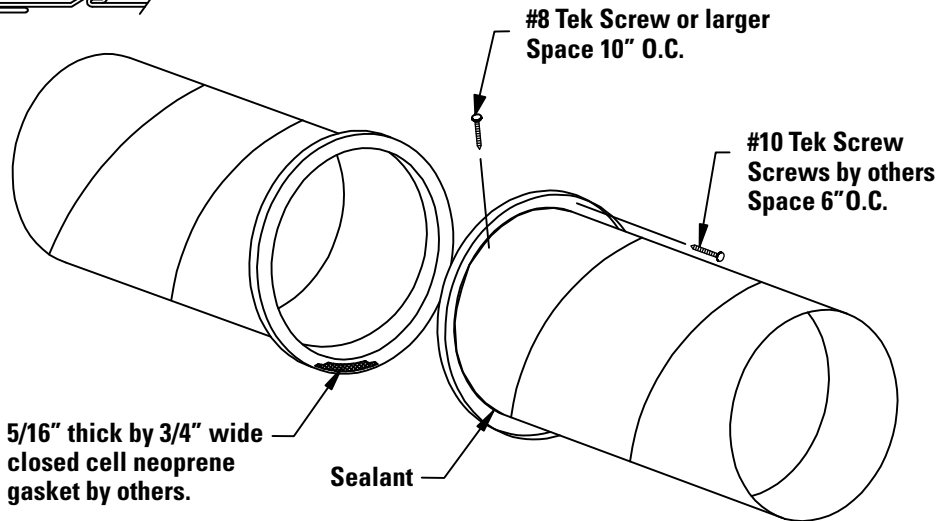

### AIR-Flange DOUBLE WALL

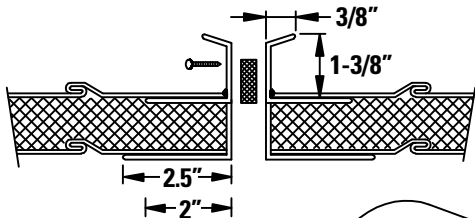

5/16" thick by 3/4" wide closed cell neoprene gasket by others. Gasket to be installed on outer flange.

